

Activation of complement in human serum by polyurethane having PEO–PTMO–PEO as soft segment

YUKO IKEDA*, SHINZO KOHJIYA*, SHINZO YAMASHITA*, HIROSHI FUKUMURA‡

*Departments of *Material Science and ‡Polymer Science and Engineering, Kyoto Institute of Technology, Matsugasaki, Kyoto 606, Japan*

Complement activation induced by segmented polyurethane and polyurethaneurea was studied. The polymers were synthesized from ABA-type triblock copolyether as a prepolymer, where A represents poly(ethylene oxide) (PEO) and B represents poly(tetramethylene oxide). The PEO contents in the triblock copolyethers were 0, 31 and 62 mol%. The whole complement in serum was activated via the classical and the alternative pathways. The contribution of the fourth complement component (i.e. the classical pathway) became larger with increasing PEO content in the polymers, due to the increased hydrophilicity of the polymer surface. The activation of the alternative pathway was affected by the concentration of NH groups and the degree of swelling of the polymer.

1. Introduction

The early research devoted to blood-compatible biomedical materials was essentially concerned with the prevention of thrombus formation, which was initiated by a direct contact of blood and the surface of materials. Recently, other adverse reactions on the interface have been found to be important with the development of various biomedical materials. Among them the activation of the complement system in blood on the surface of polymeric materials has been recognized to be one of the factors determining their biocompatibility. In the extracorporeal circulation the early reduction of leukocyte counts has been noted, since it was first described in 1960 [1]. This leukocyte reduction was demonstrated to be due to the complement activation via an alternative pathway [2]. It was estimated that activated complement components produced intravascular granulocyte aggregates, which were entrapped in the lung.

From these backgrounds, various polymers, which were used for extracorporeal circulation, were evaluated for their activation of complement system [3, 4]. In addition to these early results, several studies have recently disclosed the relationship between the chemical structure of the polymer surface and the activation mechanism of the complement system. For example, the effects of hydroxyl groups [5–8], ionic groups [9–13], crystallinity [14] and hydrophilic or hydrophobic character [14, 15] of the polymer surfaces were investigated. The relationship between blood coagulation and complement activation was also discussed [6, 12, 16–18].

Among the polymers developed for biomedical uses, polyurethanes have been known to be useful for artifi-

cial hearts and blood vessels, since Boretos and Pierce [19] reported in 1968 that a segmented polyurethaneurea showed a good thromboresistance as well as excellent mechanical properties. Segmented polyurethane and polyurethaneurea are among the thermoplastic elastomers [20] with a general structure $(A-B)_n$, where A is the hard segment and B is the soft segment, i.e. they are among multiblock copolymers. The soft segment is usually composed of a polyether or polyester chain having molecular weight between 600 and 3000. The hard segments are formed from diisocyanate and diamine or diol, which aggregate to form glassy or semicrystalline domains in the soft segment matrix. Namely, micro-phase separation is observed. At a service temperature, the soft segment matrix is in a rubbery state and the hard segment domain exhibits two functions, i.e. as a thermally reversible cross-link and as a reinforcing filler. The micro-phase separation in multiblock copolymers is schematically shown in Fig. 1. The isolated particles of hard segment domains, which are indicated by cyclic broken lines, are dispersed in the continuous phase of soft segment matrix.

A good thromboresistance and excellent mechanical properties of polyurethanes are explained in terms of their micro-phase separated structure [21–24]. Among biomedical materials, Biomer® is the most well known, and it was used as one of the raw materials to fabricate the implantable artificial hearts [25]. Biomer® is chemically a segmented polyurethaneurea (SPUU) prepared from hydroxyl-terminated poly(tetramethylene oxide) (HT-PT), 4,4'-diphenylmethane diisocyanate (MDI) and ethylenediamine (ED). Pellethane® is a commercially available biomedical grade segmented polyurethane prepared from

TABLE I Properties of segmented polyurethanes and polyurethaneureas

Sample code	Prepolymer			CTI ^d	Swelling (%)	NH ^e (wt %)
	M_n^a	M_w/M_n^b	PEO content ^c (mol %)			
SPU-2	1830	1.5	0	3.5	1	2.5
SEU-3	2490	1.5	31	4.4	8	2.0
SEU-6	4040	1.3	62	4.9	59	1.3
SPUU-2	1830	1.5	0	3.6	1	3.7
SEUU-3	2490	1.5	31	4.9	7	2.9
SEUU-6	4040	1.3	62	4.3	32	2.0

^a Determined by vapour pressure osmometer.

^b Determined by gel permeation chromatography.

^c Determined by ¹H-NMR spectroscopy.

^d Coagulation time index measured by the Lee-White method (*in vitro* test) [31, 35].

^e NH group content from the feed composition.

2.3. *In vitro* measurement of complement activation

The glass beads coated with the sample polymer were used for the *in vitro* measurement of complement activation [14, 36]. Glass beads (meshed, and collected beads between 48 and 60 mesh, diameter ~ 270 μm) were soaked in the polymer solution (0.50 wt % polymer in *N,N'*-dimethylacetamide (DMAc)). After filtration, the beads were kept at 60 °C to evaporate the solvent. This coating procedure was repeated three times and finally the coated beads were subjected to drying under a reduced pressure at room temperature. The beads were immersed in gelatin veronal buffer (GVB) for 2 h at room temperature, and 1.0 ml normal human serum (NHS) was added. The mixture (the ratio, surface area of the beads/NHS = 200 cm² ml⁻¹) was incubated at 37 °C for 1 h. CH₅₀, i.e. 50% haemolytic unit of complement, of the serum after the contact with polymer-coated beads was assayed according to the Mayer's method [38]: 3.0 ml GVB solution of the reacted NHS and the sheep

erythrocytes which optimally sensitized with whole rabbit antiserum (EA) were incubated for 1 h at 37 °C. The absorbance at 541 nm of the supernatant solution was measured to assay 50% lysis. The outline of this measurement is shown in Fig. 3. As a reference, CH₅₀ of the serum without mixing with the beads (CH₅₀(ref.)) was measured, and the decrease in CH₅₀ is calculated as follows

Decrease of CH₅₀ (%)

$$= \frac{\text{CH}_{50}(\text{ref.}) - \text{CH}_{50}}{\text{CH}_{50}(\text{ref.})} \times 100 \quad (2)$$

The larger the decrease of CH₅₀, the more active is the polymer for the activation of the complement system.

Haemolytic activity of the fourth complement (C4) was determined by the method of Gaither *et al.* [39]: 3.0 ml GVB solution of the reacted NHS, EA and C4-deficient sera were incubated at 37 °C for 1 h. After the termination by the buffer solution containing disodium ethylenediaminetetraacetate (EDTA), the as-

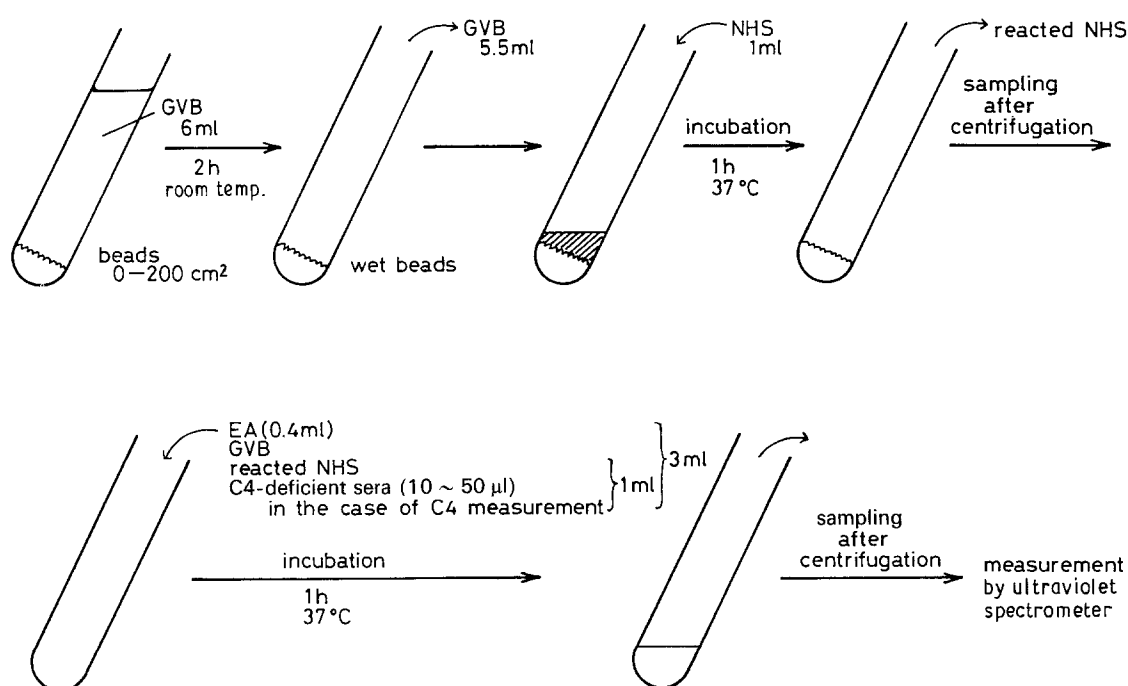

Figure 3 Experimental procedure for the complement activation in normal human serum by the beads method.

say of 50% lysis was conducted by ultraviolet spectrometry. The larger the decrease of C4 activity, the greater is the classical pathway activated.

3. Results and discussion

3.1. Activation of the whole complement system

CH₅₀ is an indicator which shows the activation of the whole complement system by the polymer covering the glass beads. The decreases of CH₅₀ for segmented polyurethanes and polyurethaneureas are shown in Fig. 4. In both the segmented polyurethanes and the polyurethaneureas, it is noted that the decreases of CH₅₀ in serum become larger with increasing PEO content. However, it is also noticeable that the decreases observed for all the present polyurethanes were much smaller than those for ethylene-vinyl alcohol copolymer having 32% ethylene (EVAL-32) and cellulose.

The increase of PEO content is associated with the increase of hydrophilicity of these polymers. The complement system is considered to be activated by the enhancement of the hydrophilicity of soft segment matrix. The results of this study is in accord with the general trend [14, 15], i.e. the hydrophobic surface did not activate the complement system, while the hydrophilic one did. The decrease of CH₅₀ by the segmented polyurethane was less than that by segmented polyurethaneurea when compared with the same PEO content samples. The reason for this difference and the observed applicability of the general trend are discussed in the next section in relation to the mechanism of complement activation.

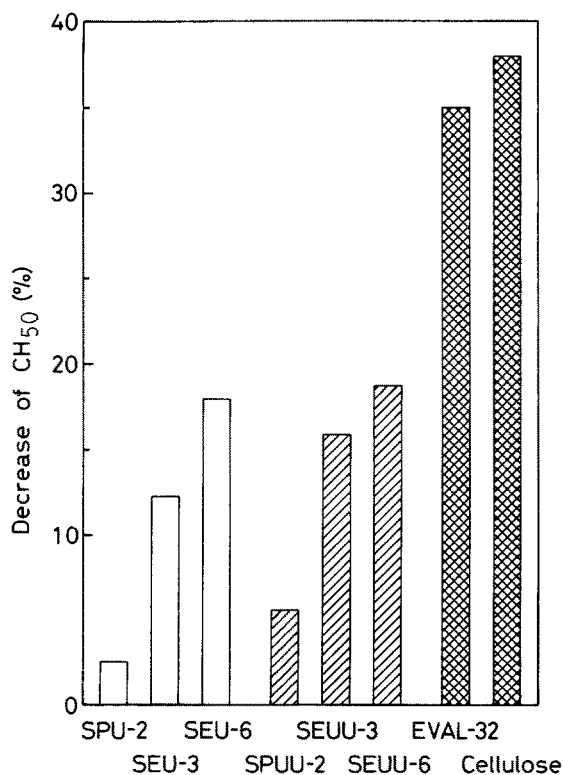

Figure 4 Decrease of CH₅₀ for segmented polyurethanes and polyurethaneureas. The results for EVAL-32 and cellulose are taken from [14].

3.2. Mechanism of complement activation: experimental results

It is well known that the complement activation takes place via two routes, i.e. the classical and the alternative pathways [40], which are depicted in Fig. 5. In this study, the haemolytic activity of C4 was measured by Gaithers' Method in order to elucidate the mechanism of complement activation. The cleavage of C4 by the activated C1 is specific for the classical pathway. The results of the measurement of C4 activity are shown in Fig. 6. The activation of C4 became more predominant with increasing PEO content both in the segmented polyurethane and in the segmented polyurethaneurea. The result showed that the larger the PEO content, the greater the activation via the classical pathway.

In Fig. 7, the activation of the whole complement system against PEO content is shown together with the contribution of each pathway. The change of the activation of the classical pathway showed the same tendency as that of the whole complement system. The dotted line in this figure shows the contribution of the alternative pathway to the whole complement activation, which was obtained from the difference between the decrease of CH₅₀ and the decrease of C4. The activation of the classical pathway by SPU-2 and SPUU-2 was not detected. In other words, only the alternative pathway worked if hydrophilic PEO units were absent in the polymers. However, both classical and alternative pathways were activated in the polymers containing PEO units.

3.3. Mechanism of complement activation: discussion

The results in Fig. 7 indicate that the hydrophilicity of the polymer was very influential on the mechanism of complement activation. This effect is interpreted by considering three factors: the adsorption of γ -immunoglobulin G (IgG), the reaction of NH groups with C3, and the effect of swelling of the polymers. Each factor is explained in detail.

The IgG-coated surface is known to activate the complement in a manner very similar to the activation by the immune complex [41, 42]. The deposition of IgG on to a foreign surface may create a "pseudo antigen-antibody" complex which activates the classical pathway [7]. The molecule of IgG is Y-form and consists of an F_{ab} part and an F_c part. F_{ab} relates to the antigen-antibody reaction and F_c is responsible for the reaction with complement or the cell which has an F_c receptor. It is anticipated that the F_{ab} part is hydrophilic, but F_c is hydrophobic [43]. With the increase of hydrophilicity of the present polymer surface by the introduction of the PEO segment, IgG would become adsorbed on the polymer surface, in such a manner that its hydrophilic F_{ab} would orient towards the polymer surface and its hydrophobic F_c would orient towards the blood, as shown in Fig. 8 [44]. As the results of its selective orientation of IgG, the classical pathway of complement might be activated on SEU or SEUU as illustrated in this figure.

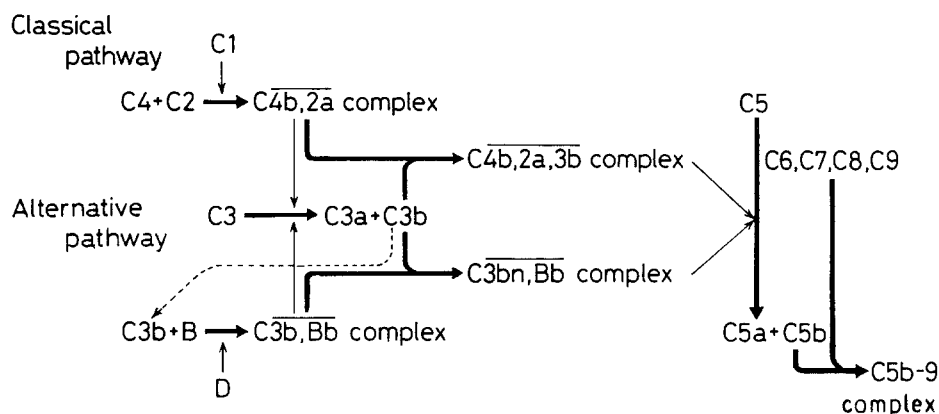

Figure 5 Mechanism of the activation of complement system: the classical and alternative pathways.

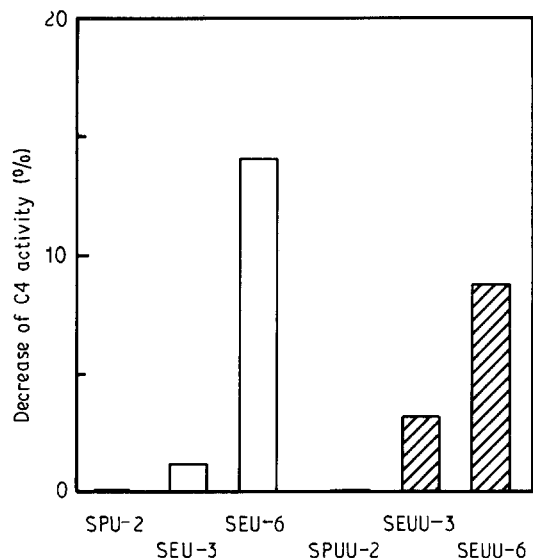

Figure 6 Decrease of C4 activity for segmented polyurethanes and polyurethaneureas.

It was also reported [17] that the protein in serum, tended to physically and weakly bond to the surface of segmented polyurethaneurea having a PEO segment, and was more liable to desorb from it compared with that without a PEO segment. The deformation of protein becomes difficult on the hydrophilic polyurethane. Therefore, the IgG receptor for the complement activation is not considered to be appreciably deformed on the hydrophilic SEU or SEUU surface. This will also be one of the factors for the activation of C4.

The complement activation via the alternative pathway involves substances which are able to bind directly to the third component of complement (C3), and this reaction occurs through a transesterification of the protein fragment C3b with a nucleophilic group, like sugar or primary amine [45].

In the case of polyurethane, NH groups are present in their hard segments. Therefore, its NH group may activate the alternative pathway. Fig. 9 shows our estimation of how NH groups activate the alternative pathway. It is estimated that the larger the concentration of free NH groups on the surface, the greater is the activation via the alternative pathway. Hence the alternative pathway is speculated to be more activated

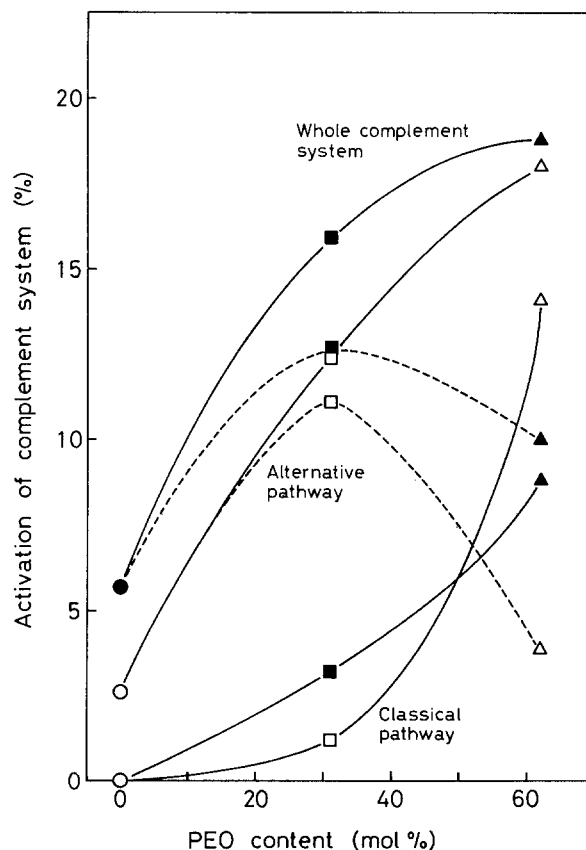

Figure 7 The complement activations as a function of the PEO content in the segmented (\circ , \square , \triangle) polyurethanes and (\bullet , \blacksquare , \blacktriangle) polyurethaneureas.

by the segmented polyurethaneurea than by the segmented polyurethane (see Table I for the NH group contents). In fact, the segmented polyurethaneureas showed a higher activation of the alternative pathway than the segmented polyurethanes, when compared with the same PEO content samples (see Fig. 7). However, the effect of hard segment content did not seem to affect linearly its activation, as seen in Fig. 7.

To explain this non-linearity, the effect of swelling is taken into account: the degrees of swelling of SEU-6 and SEUU-6 were larger than those of SPU-2 and SPUU-2, although the weight percentages of NH groups in SEU-6 and SEUU-6 were smaller than those of SPU-2 and SPUU-2. The NH groups in the

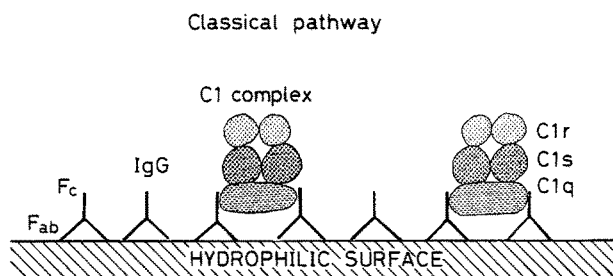

Figure 8 The initiation of the complement activation via the classical pathway on SEU or SEUU.

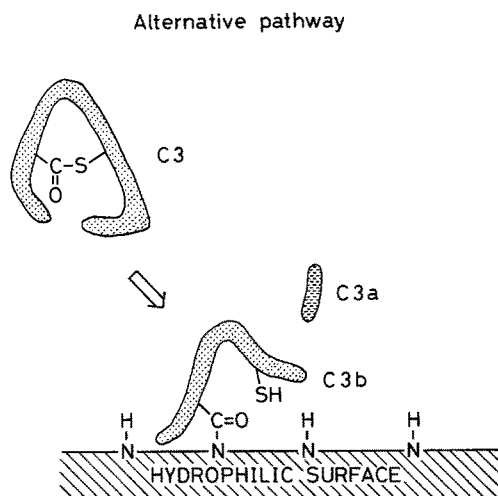

Figure 9 The mechanism of initiation of the complement activation via the alternative pathway on SEU and SEUU.

highly swollen polymer surface became free from hydrogen bonding among hard segments, and resulted in hydration. Thus the concentration of these free NH groups affected the activation via the alternative pathway.

3.4. The relationship between antithrombogenicity and complement activation

The relationship between the thrombus formation and the activation of complement system was recently discussed by several researchers [6, 12, 16–18]. Yet, none of the discussions seemed to be conclusive enough to establish a final relationship. Through these studies it is recognized as a trend that the complement activation was suppressed on the surfaces of antithrombogenic biomaterials.

Fig. 10 shows the relationship between the coagulation time index (CTI) [31, 35] and the decrease of CH_{50} of segmented polyurethanes and polyurethaneureas used in this study. This figure suggests that the more antithrombogenic the polymer (the larger CTI), the greater is the activation of complement (the larger the decrease of CH_{50}) with the exception of SEUU-6. This tendency seems to be contrary to the above-mentioned trend. In order to explain this difference, it is necessary to take the effect of serum protein adsorption into account. Among the many kinds of serum

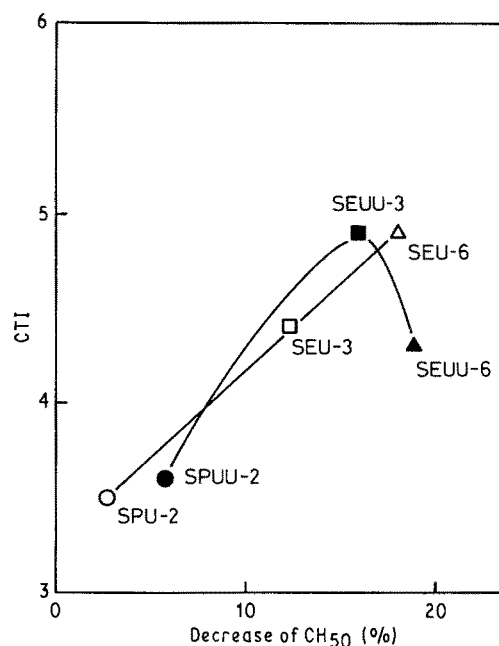

Figure 10 The relationship between antithrombogenicity and complement activation of segmented (\circ , \square , \triangle) polyurethanes and (\bullet , \blacksquare , \blacktriangle) polyurethaneureas. (\circ , \bullet) 0 mol % PEO content, (\square , \blacksquare) 31 mol % PEO content, (\triangle , \blacktriangle) 62 mol % PEO content.

protein the amount of albumin is the largest ($\sim 60\%$), followed by IgG and fibrinogen. As these three kinds of protein comprise 70% of the serum protein, it is important to consider their interaction with the polymer surface.

The adsorption of the F_{ab} part of IgG on the hydrophilic surface on SEU or SEUU caused the F_c part of IgG to orient towards blood, which activated the complement system as previously mentioned. It can be considered that the F_c part simultaneously activated platelets, because the F_c part has a saccharide segment and the specific reactions between F_c and complement or platelet occurred. Their specific reactions are not reported when the F_{ab} part of IgG oriented towards blood [46]. The degree of whole complement activation on the hydrophilic SEU or SEUU was under 20%. Therefore it would be expected that the platelet activation on these polymer surfaces by the F_c part was also not very important, because the concentration of IgG in serum protein is lower than that of albumin.

Generally it was reported that the polymer surface, on which albumin was liable to be adsorbed, showed good antithrombogenicity [47]. In the report on micro-phase separated polymer surfaces, albumin was found to be selectively adsorbed on the hydrophilic domain [44]. Therefore, in our study it was assumed that the improvement of antithrombogenicity on SEU or SEUU by the introduction of hydrophilic PEO units was brought about by the adsorption of albumin, which exists in serum protein as the major fraction. The effect of the F_c part for the platelet activation would be much lower than that of albumin. In relation to this explanation, the adsorptions and the deformations of platelets on SEUU-3 and on SPUU-2 are shown in Fig. 11. On the surface of more hydrophilic SEUU-3, both the adsorption and the deformation of platelets were found to be less than on

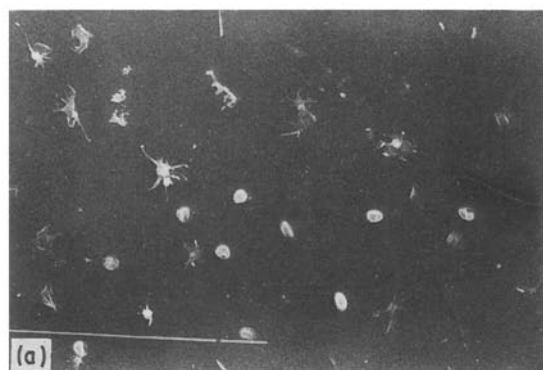

Figure 11 Scanning electron micrographs of platelets adhered to the surfaces of (a) SPUU-2 and (b) SEUU-3.

SPUU-2. This result is also explained by the selective protein adsorption. The lowering of antithrombogenicity of SEUU-6, as shown in Fig. 10, is not explained by the discussions so far. At present we may only point out a probable reason as follows: the polymeric materials which induce many C3b fragments (i.e. the greater the activation of the complement system) were reported to promote the thrombus formation mediated by leukocytes [18]. This mediation resulted in the lowest antithrombogenicity of SEUU-6 because SEUU-6 showed the highest decrease of CH_{50} (i.e. the highest activation of the complement system) among the polymers examined in this report.

4. Conclusion

The activation of the complement system on the antithrombogenic segmented polyurethanes and polyurethaneureas having PEO-PTMO-PEO as the soft segment became larger with increasing hydrophilicity of the polymer surface. This trend was due to the activation via the classical pathway. The activation of the alternative pathway was affected by the concentration of NH groups and swelling of the polymers. As shown in Fig. 4, the complement activations induced by SEU and SEUU were lower than that by EVAL-32 [14], which is now utilized in a dialyser. Therefore, it seems to be justifiable to say that the extent of complement activation by SEU and SEUU is not so great as to annul their good blood compatibilities for use as biocompatible materials.

References

1. Y. MITO, A. NISHIMURA, A. SUMIYOSHI, M. KAWAI, Y. NOSE, Y. KAWAMURA and C. YOSHIMOTO, *Sogoigaku (General Medicine)* **17** (1960) 538 (in Japanese).
2. P. R. CRADDOCK, J. FEHR, A. P. DALMASSO, K. L. BRIGHAM and H. S. JACOB, *J. Clin. Invest.* **59** (1977) 879.
3. P. ALJAMA, P. A. E. BIRD, M. K. WARD, T. G. FEEST, W. WALTER, H. TANBOGA, M. SUSSMAN and D. N. S. KERR, *Dialysis Transplant Neurol.* **15** (1978) 144.
4. D. E. CHENOWETH, A. K. CHEUNG and L. W. HENDERSON, *Kidney Int.* **24** (1983) 764.
5. D. E. CHENOWETH, *Artif. Organs* **8** (1984) 281.
6. A. MAHIOUT, H. MEINHOLD, M. KESSEL, H. SCHULZE and U. BAURMEISTER, *ibid.* **11** (1987) 149.
7. M. S. PAYNE and T. A. HORBETT, *J. Biomed. Mater. Res.* **21** (1987) 843.
8. M. P. CARRENO, D. LABARRE, M. JOZEFOWICZ and M. D. KAZATCHKINE, *Mol. Immunol.* **25** (1988) 165.
9. T. E. HUGLI and D. E. CHENOWETH, in "Immunoassays: Clinical Laboratory Techniques for the 1980s", edited by R. Nakamura, W. R. Dito and E. S. Tucker (Freeman, New York, 1980) p. 433.
10. B. CREPON, F. MAILLET, M. D. KAZATCHKINE and J. JOZEFONVICZ, *Biomater.* **8** (1987) 248.
11. T. MATSUDA, H. IWATA, H. TAKANO, T. AKUTSU, T. KISHIMOTO, S. YAMAGAMI and M. MAEKAWA, *Jpn J. Artif. Organs* **17** (1988) 515.
12. A. NAKAO, H. TAKAGI and S. NAGAOKA, *ibid.* **17** (1988) 574.
13. K. B. M. REID and R. R. PORTER, *Ann. Rev. Biochem.* **50** (1981) 433.
14. S. YOSHIKAWA, H. FUKUMURA, Y. AKAGAKI and S. INAI, in "Advances in Biomaterials", Vol. 8, "Implant Materials in Biofunction", edited by C. de Putter, G. L. de Lange, K. de Groot and A. J. C. Lee (Elsevier Science, Amsterdam, 1988) p. 187.
15. T. MATSUDA, M. NIINOBE and H. IWATA, *Jpn J. Artif. Organs* **16** (1987) 1045.
16. H. FUKUMURA, K. HAYASHI, S. YOSHIKAWA, M. MIYA, N. YAMAMOTO and I. YAMASHITA, *Biomater.* **8** (1987) 74.
17. T. MATSUDA, K. IMACHI and T. AKUTSU, *Jpn J. Artif. Organs* **18** (1989) 114.
18. K. HAYASHI, H. FUKUMURA and N. YAMAMOTO, *J. Biomed. Mater. Res.*, in press.
19. J. W. BORETOS and W. S. PIERCE, *ibid.* **2** (1968) 121.
20. W. MECKEL, W. GOYERT and W. WIEDER, in "Thermoplastic Elastomers", edited by N. R. Legge, G. Holden and H. E. Schroeder (Hanser, Munich, Vienna, New York, 1987) p. 13.
21. J. W. BORETOS, W. S. PIERCE, R. E. BAIER, A. F. LEROY and H. J. DONACHY, *J. Biomed. Mater. Res.* **9** (1975) 327.
22. D. J. LYMAN, B. KUNTSON, B. MCNEILL and K. SHIBATANI, *Trans. Amer. Soc. Artif. Intern. Organs* **21** (1975) 49.
23. D. J. HARROP, in "Developments in Rubber Technology-3", edited by A. Whelan and K. S. Lee (Applied Science, London, New York, 1982) Ch. 5.
24. D. E. GREGONIS and J. D. ANDRADE, in "Surface and Interfacial Aspects of Biomedical Polymers", Vol. 1, edited by J. D. Andrade (Plenum Press, New York, 1985) Ch. 3.
25. H. E. KAMBIC, S. MURABAYASHI and Y. NOSE, *Chem. Engng News* 14 April (1986) p. 30.
26. N. YAMAMOTO, I. YAMASHITA, K. HAYASHI and K. TANAKA, *Seitaizairyoku (Biomaterials)* **2** (1984) 99, in Japanese.
27. R. J. ZDRAHALA, D. D. SOLOMON, D. J. LENTZ and C. W. MCGARY Jr, in "Advances in Biomaterials" Vol. 7, "Biomaterials and Clinical Applications", edited by A. Pizzoferrato, P. G. Marchetti, A. Ravaglioli and A. J. C. Lee (Elsevier Science, Amsterdam, 1987) p. 621.
28. D. K. PARK, T. OKANO, C. NOJIRI and S. W. KIM, *J. Biomed. Mater. Res.* **22** (1988) 977.

29. D. K. HAN, S. Y. JEONG and Y. H. KIM, *ibid.* **23** (1989) 211.
30. S. Q. LIU, Y. ITO and Y. IMANISHI, *J. Biomater. Sci. Polym. Ed.* **1** (1990) 111.
31. Y. IKEDA, S. KOHJIYA and S. YAMASHITA, *Rubber World* **200** (1989) 21.
32. S. KOHJIYA, S. TAKESAKO, Y. IKEDA and S. YAMASHITA, *Polym. Bull.* **23** (1990) 299.
33. Y. IKEDA, S. TAKESAKO, S. KOHJIYA and S. YAMASHITA, *Biomater.* **8** (1990) 553.
34. Y. IKEDA, S. KOHJIYA, S. YAMASHITA, N. YAMAMOTO, K. HAYASHI and I. YAMASHITA, *Nippon Kagaku Kaishi (J. Chem. Soc. Jpn)* (1986) 699, in Japanese.
35. S. KOHJIYA, Y. IKEDA and S. YAMASHITA, in "Polyurethanes in Biomedical Engineering II", edited by H. Plank, I. Syre, M. Douner and G. Egbers (Elsevier Science, Amsterdam, 1987) p. 183.
36. Y. IKEDA, S. KOHJIYA, S. YAMASHITA, H. FUKUMURA and S. YOSHIKAWA, *Polymer J.* **20** (1988) 273.
37. Y. IKEDA, S. KOHJIYA, S. YAMASHITA, H. HAYASHI and T. OKUNO, *Nihon Reoroji Gakkaishi (J. Soc. Rheol. Jpn)* **18** (1990) 12, in Japanese.
38. M. M. MAYER, in "Experimental Immunochemistry", 2nd edn, edited by E. A. Kabat and M. M. Mayer (Thomas, Springfield, IL 1961) p. 133.
39. T. A. GAITHER, D. W. ALLING and M. M. FRANK, *J. Immunol.* **113** (1974) 574.
40. N. TAMURA, "Hotaigaku (Complement)", edited by S. Inai, K. Inoue and N. Tamura (Ishiyakushuppan, Tokyo, 1987) p. 8.
41. K. ISHIZAKI, *Progr. Allergy* **7** (1963) 32.
42. T. UCHIDA, S. HOSAKA and Y. MURAO, *Biomater.* **5** (1984) 281.
43. S. J. VAN OSS, C. F. GILLMAN and A. W. NEWMAN, in "Phagocytic Engulfment and Adhesiveness as Cellular Surface Phenomena" (Marcel Dekker, New York, 1975).
44. M. OKANO, S. NISHIYAMA, K. SHINOHARA, T. AKAIKE and Y. SAKURAI, *Koubunshi Ronbunshu (J. Polym. Soc. Jpn)* **36** (1979) 209, in Japanese.
45. S. K. A. LAW, T. M. MINICH and R. P. LEVINE, *Biochem.* **20** (1981) 7457.
46. C. KIYOTAKI, *Naika (Intern. Med.)* **42** (1978) 346, in Japanese.
47. D. J. LYMAN, L. C. METCALF, D. ALBO, Jr., K. F. RICHARDS and J. LAMB, *Trans. Amer. Soc. Artif. Intern. Organs* **20B** (1974) 474.

*Received 12 July
and accepted 31 July 1990*